

All information on this drawing is proprietary and may not be reproduced in any manner or made available to any unauthorized person/party without written permission of ALPHA PRODUCTS, INC.

REVISIONS			
REV.	DESCRIPTION	DATE	APPROVED

- MARKING:
- BAGGING:
- PACKING:
- LOGO (ALPHA ONLY):
- FULL LOGO:

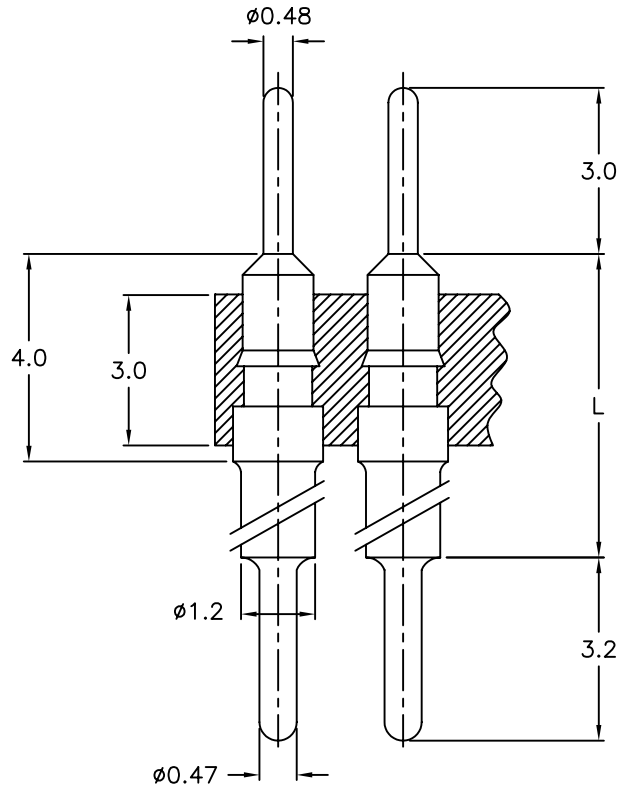

REF NUMBER	GAP (DIM "L")	PLATING
300/233C10781	6.2	TIN
300/233C10782		GOLD
300/233C10783	8.4	TIN
300/233C10784		GOLD
300/233C10785	15.3	TIN
300/233C10786		GOLD

2. ALL DIMENSIONS ARE FOR REFERENCE ONLY.  
 1. ALL DIMENSIONS ARE IN MM.

NOTES:

847		
VCN	CCN	AQE
APPLICATION		

ITEM #	QTY REQD	UNIT MEASURE	PART OR IDENTIFYING NO.	NOMENCLATURE OR DESCRIPTION	MATERIAL SPECIFICATION
PARTS LIST					
TOLERANCES (UNLESS OTHERWISE SPECIFIED)			CONTRACT NO.		 351 IRVING DR, OXNARD, CA 93030 USA TEL: (805)981-8666 FAX: (805)988-6555 E-MAIL: info@alpha-products.com
MATERIAL			APPROVALS	DATE	
FINISH			DRAWN		
			CHECKED		
			ISSUED		INTERCONNECT CONTACT FOR PRECISION IC SOCKETS
SIZE		FSCM NO.	DWG NO.		REV.
B		8U759	300/233C1078		
DO NOT SCALE DRAWING			SCALE NONE		SHEET 1 OF 1